

COOL AIR

(763) 205-0844

INCORPORATED

Ammonia Leak Detection Systems



Electrochemical Sensor



Models

ELECTROCHEMICAL SENSOR ONLY

LBW-420-EC (115VAC powered)

LBW-420-1-EC (24VDC powered)

LBW-420-2-EC (230VAC powered)

Firmware 7-30

TABLE OF CONTENTS

IMPORTANT—READ THIS FIRST	4
CAUTIONS	4
AVOIDING NUISANCE ALARMS	5
INTRODUCTION	5
STANDARD FEATURES	6
PARTS DESCRIPTION	8
FRONT PANEL DISPLAY	8
AMMONIA SENSOR	9
FRONT PANEL-MOUNTED CIRCUIT BOARD	9
SERVICE SWITCH (SERVICE MODE)	10
THE “ENTER”, “UP”, AND “DOWN” PUSHBUTTONS	10
ROTARY SELECTOR SWITCH	10
ENCLOSURE-MOUNTED CIRCUIT BOARD	13
POWER (LBW-420)	13
POWER (LBW-420-1)	13
JUMPER J3, AMMONIA SIGNAL (LBW-420-1 ONLY)	13
RELAYS	14
RELAY STATUS LEDs	15
EXTERNAL CONNECTIONS	15
4–20 MA ANALOG OUTPUT	15
INSTALLATION AND SETUP	19
PROGRAMMING AND OPERATION	20
SETTING THE DESIRED DISPLAY MODE	21
PROGRAMMING THE AMMONIA HI-ALARM AND LOW ALARM SET POINTS	21
PROGRAMMING THE EXTERNAL TEMPERATURE SENSOR INSTALLATION STATUS	22
PROGRAMMING THE 4–20 MA RANGE	23
SETTING THE SERVICE MODE TIMEOUT	23
SETTING THE AUXILIARY RELAY PAIRING	24
SETTING THE RELAY LATCHING	24
RE-SETTING A LATCHED RELAY	25
ERROR CODES	25
MESSAGE CODES	25
4–20 MA ERROR INDICATION	25

TEST AND CALIBRATION26

TESTING THE DETECTOR..... 26

CALIBRATING THE DETECTOR 27

ZERO OFFSET ADJUST 27

WHEN INSTALLING A NEW SENSOR 28

TECHNICAL SUPPORT 29

WARRANTY..... 30

LBW-420, LBW-420-1 and LBW-420-2 SPECIFICATIONS

Ammonia Detection Sensitivity	0 to 500 PPM
Display	0.8", 7-segment LED, 4-digit
Controls	Service mode jumper Enter, Up, and Down pushbuttons Rotary selector switch Jumper
Ammonia Sensor - Electrochemical	* High selectivity to NH3 * Small influence by H2S * Excellent durability to NH3 exposure * Linear output * Long life * Stable baseline * Unique leak-proof structure
Relays	Alarm, pre-alarm, and auxiliary (see pairing aux relay) Form C (SPDT), normally-open, normally-closed, energized in normally-open state latching or non-latching. Contact rating: 5A, 120 VAC or 24
Outputs	Contacts for: alarm, pre-alarm, and auxiliary relays, and external temperature sensor 4-20 mA DC, conforming to S50.01 ratings. Type 2L and Type 2H
Operating Temperature	-20°F to 110°F - The detector will function outside of this range. However, the EC sensor life will be significantly shortened at higher temperatures.
Operating Humidity	5% to 95% RH, non-condensing
Power Requirements	LBW-420 115VAC, 50/60 Hz 0.5 Amps max. LBW-420-1 24Volts DC, 21.6 – 26.4, +/- 10% 0.5 Amps max. LBW-420-2 230VAC, 50/60 Hz 0.5 Amps max.
Dimensions	9½" H x 8" W x 4½" D
Weight	6 lbs.
Enclosure	NEMA 4X rated, UL listed
Pollution Degree	1
Approvals LBW-420 115VAC and LBW-420-1 24VDC	Tested to UL 61010-1:2004 R7.05 CAN/CSA-C22.2 61010-1:2004  By TUV Certificate no. CU72090607 01
Options	1. Remote ammonia sensor with box and cable (500 ft. max.) 2. Temperature (F) sensor with cable 3. External back-up battery 4. ABS washdown tube 5. Remote alarm light and horn unit with box, cable, & TEST/NORMAL/SILENCE toggle switch.

IMPORTANT—READ THIS FIRST

PLEASE READ AND UNDERSTAND THIS SECTION BEFORE INSTALLING AND OPERATING THE LBW-420 DETECTOR.

Note: This manual is specific to an LBW-420 with an Electrochemical sensor installed, it is possible to do a field conversion to a Solid-State Sensor. Contact Cool Air Incorporated sales - sales@coolairinc.com or 763-205-0844 for more information.

CAUTION:



WARNING: RISK OF ELECTRIC SHOCK. DO NOT REMOVE COVER. NO USER SERVICEABLE PARTS INSIDE. REFER TO QUALIFIED SERVICE PERSONNEL.

AVIS: RISQUE DE CHOC ELECTRIQUE. NE PAS ENLEVER LE COUVERCLE. AUCUN ENTRETIEN DE PIECES INTERIEURES PAR L'USAGER. CONFIER L'ENTRETIEN AU PERSONNEL QUALIFIE.

After applying power, test the detector to ensure it is operating correctly. Be sure the detector has been powered for at least 20 minutes before testing.

Do not store this manual inside the detector, as this might result in damage to components from excessive heat.

Adequately cover the detector sensor during washdown and avoid spraying the washdown liquid directly onto the sensor. If necessary, an ABS wash down tube is available from the factory.

Avoiding Nuisance Alarms

To avoid nuisance alarms, place the detector in service mode before:

- Programming set points and external temperature sensor installation status.
- Performing maintenance, repairs, testing, or calibration.
- Performing refrigeration system maintenance.
- Removing the ammonia or temperature sensor.

Furthermore, be sure of the following before placing the detector in normal operating mode:

- The ammonia concentration reading is below the Low-alarm set point.

A nuisance alarm will also occur if the external temperature sensor installation status is programmed to “F In” (installed) and an external temperature sensor is not installed.

INTRODUCTION

The Cool Air Incorporated LBW-420 Family of Detectors is a state-of-the-art ammonia leak detector that detects and displays ammonia concentrations of 0 to 500 parts per million (PPM) electrochemical sensor or 0 to 1000 parts per million (PPM) solid state sensor.

The Cool Air Incorporated LBW-420-2 is a 230VAC powered version of the LBW-420 ammonia leak detector (115VAC powered detector). The LBW-420-2 requires an AC supply voltage between 200- and 240-volts AC.

The Cool Air Incorporated LBW-420-1 is a DC powered version of the LBW-420 ammonia leak detector (AC powered detector). The LBW420-1 incorporates a fully isolated DC to DC power supply, allowing the LBW-420-1 to be powered from the same DC supply as the 4-20 mA monitoring circuits without concern for ground isolation.

The LBW-420-1 requires a DC supply voltage between 18- and 36-volts DC.

The LBW-420-1 can be configured to supply power to the 4-20 mA circuit(s) or can operate as a fully isolated 4-20 mA sensor. Refer to **4–20 mA Analog Outputs** for more details.

STANDARD FEATURES

All LBW-420's come with these additional standard features:

- Programmable Hi Alarm and Low-Alarm set points.
- Selectable PPM reading start (0PPM, 10PPM, or 25PPM)
- The detector hardware and the connected system response can be tested without exposing the sensor to ammonia.
- Selectable Service Mode timeout.
- 4-20 mA analog output signals, for ammonia which can communicate directly with computer systems such as PLC's.
- Normally-open, normally-closed contacts for communicating with common industry alarm systems.
 - Can be set to latch or not
- A NEMA 4X, UL-listed enclosure.
- Spare contacts for operating auxiliary equipment such as exhaust fans, king valves, compressors, and additional alarm systems.
 - This relay can be set to operate as an indication of an error only, error and active with low alarm relay or error and active with alarm relay.
 - Can be set to latch or not

In addition to the standard features, the LBW-420 and LBW-420-1 can be equipped with these options:

- A remote ammonia sensor with cable allowing the sensor to be located a maximum of 500 feet away from the detector.
- An external back-up battery to keep the detector working during loss of main power.
- External Temperature Sensor (display only, NO 4 to 20mA output)
- RLV connection, for monitoring Relief Line vents

- An ABS wash-down tube installed over the sensor so that it does not get wet during washdown.
- A remote alarm light and horn box with a toggle switch to TEST/NORMAL/SILENCE the alarm.
- A Remote service switch

Contact Cool Air Incorporated technical support for more detailed information, or for purchasing, any of these options.

PARTS DESCRIPTION

Front Panel Display

The front panel display is comprised of a digital display and a series of labeled indicating LED's. The seven-segment, four-digit display indicates a variety of information, such as ammonia concentration and external temperature (if an external temperature sensor is in use), and more, depending on the position of the rotary selector switch. Ammonia concentration is displayed in parts per million and temperature is displayed in degrees Fahrenheit ("F"). The LEDs provide an indication of ammonia concentration and alarm status at a glance.

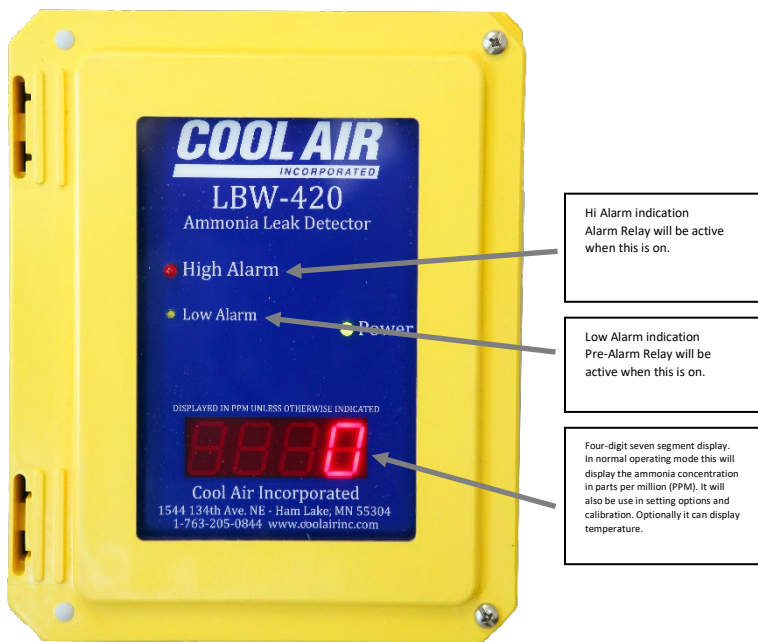

For information on how the display indicates ammonia concentrations, see the sections on ammonia leak indication.

Ammonia Sensor

The detector comes with an Electrochemical, long-life sensor that has a high selectivity and a quick response to concentrations of ammonia. The sensor is temperature compensated and is protected by an inexpensive pre-filter that is easy to replace.

Front Panel-Mounted Circuit Board

The front panel-mounted circuit board contains the controls necessary for programming and operating the detector. Each control is described in detail below. When the detector enclosure is open, this circuit board is on the left, attached to the front panel.

NOTE: The service switch may be a jumper instead of the switch.

LBW-420 and LBW-420-1 Ammonia Leak Detectors

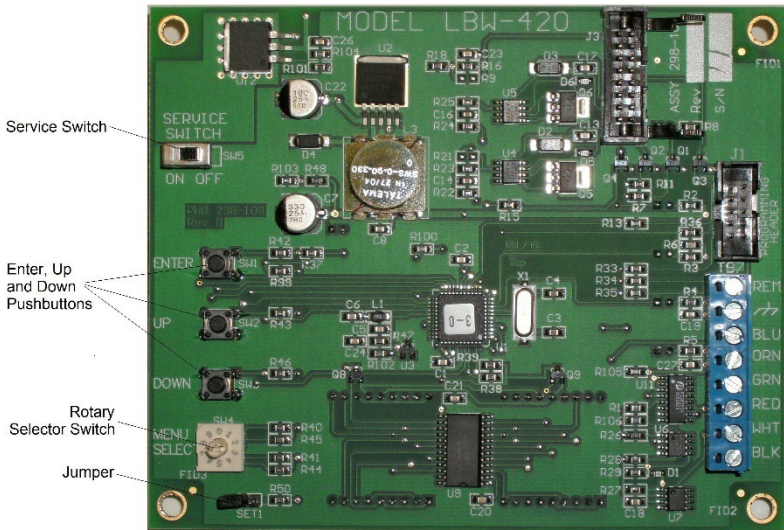

Front Panel-Mounted Circuit Board

Service Jumper (Service Mode)

The detector can be set to one of two modes: normal operating mode or service mode. The detector is in normal operating mode when the service jumper is in the “OFF” position. When the service jumper is in the “ON” position, the detector continues to function as usual, however the alarm, pre-alarm, and auxiliary relays are disabled as well as the 4 to 20mA signal is set to 4ma (0PPM). This allows the detector to be serviced, tested, and calibrated without tripping the alarm relays and setting off nuisance alarms.

When the detector is in the service mode, the display will alternate between the sensor reading in PPM and “SEr” (service jumper “on”). This is done as a reminder to set the jumper back to “off” when service is done. If the service jumper is not returned to off, it will automatically return to an as off state after a selected amount of time. The factory default is 1 hour.

See “Setting the Service Mode Timeout”

The “ENTER”, “UP”, and “DOWN” Pushbuttons

The “UP” and “DOWN” buttons are used for setting the digital display to the desired value, and the “ENTER” button is used for programming a value previously set on the digital display. These buttons are used when programming: the set points, the external temperature sensor installation status, they are also used during calibration of the detector.

Rotary Selector Switch

The rotary selector switch (labeled “MENU SELECT” on the front panel-mounted circuit board) is used for performing functions such as:

- Setting the information displayed on the front panel
- Programming set points
- Displaying system information
- Calibrating the detector

When the detector is in operation, this switch is typically set to position “0” to continuously display ammonia concentration, or to position “1” to display ammonia concentration and an external temperature (if an external temperature sensor is in use). If the switch is set to position “1”, the display will alternate between ammonia concentration and external temperature.

Use the following chart to select the switch position for the desired function:

To:	Set the Rotary Selector Switch to:
Display ammonia concentration in PPM	0
Display ammonia concentration in PPM and external temperature in °F (if an external temperature sensor is in use)	1
Display the firmware revision	2
Program the ammonia High alarm set point	3
Program the ammonia Low alarm set point	4
Display ammonia concentration in PPM (See Section Testing the Detector)	5
Auxiliary Relay latching Yes/No	6
Pre-Alarm (low alarm) Relay latching Yes/NO	7
Alarm Relay (High Alarm) Latching Yes/No	8
Factory Use	9

Note: If the rotary selector switch is left in a position other than “0” or “1” and/or the “SET1” jumper is left on for more than 5 minutes without pressing an “UP” or “DOWN” button, the digital display will begin to display ammonia concentration. If this happens, return the selector switch to the “0” position and remove the “SET1” jumper, then set the switch to the desired position. For example, if you set the rotary selector switch to position “3” to program the alarm set point, and if, after 5 minutes of inactivity the display reverts to displaying ammonia concentration, move the switch to “0”, then back to “3” to continue programming the alarm set point.

Caution: Before closing the detector enclosure, be sure to return the rotary selector switch to position “0” or “1” to correctly display ammonia concentration, or ammonia concentration and external temperature.

Additional functions are available through the rotary selector switch when the jumper (labeled “SET1”), located below the rotary selector switch on the front panel-mounted circuit board, is installed:

To:	Set the Rotary Selector Switch to:
Display ammonia sensor temperature (Solid State Sensor Only)	1
Zero adjust for the Electrochemical sensor	2
Program the ammonia sensor 4 – 20mA Range	3
Set the Service Mode Time out	4
Set the status of the External Temperature sensor (installed or not installed)	5
Sets the AUX relay pairing	6
Set the Display start value. 0PPM, 10PPM or 25PPM	7
Select for Solid State Sensor or Electrochemical Sensor	8
Calibrate the detector	9

Note: If the rotary selector switch is left in a position other than “0” or “1” and/or the “SET1” jumper is left on for more than 5 minutes without pressing an “UP” or “DOWN” button, the digital display will begin to display ammonia concentration. If this happens, return the selector switch to the “0” position and remove the “SET1” jumper, then set the switch to the desired position. For example, if you set the rotary selector switch to position “3” to program the alarm set point, and if, after 5 minutes of inactivity the display reverts to displaying ammonia concentration, move the switch to “0”, then back to “3” to continue programming the alarm set point.

Enclosure-Mounted Circuit Board

The enclosure-mounted circuit boards differ between the LBW-420/-2 and the LBW-420-1 to accommodate the differing power connections. All other connections are identical. The Enclosure Mounted Circuit board contains the relays, output contacts and termination points for connecting to external equipment. When the detector enclosure is open, this circuit board is on the rear wall of the enclosure. The enclosure-mounted circuit board is shown in the following two pictures and described in detail below. **NOTE:** This detector does not support a 4 to 20mA output for the temperature sensor.

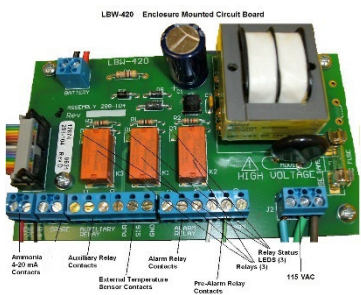

Power (LBW-420)

Power for the LBW-420 must be a nominal 115 Volt AC circuit. Power for the LBW-420-2 must be a nominal 230 Volt AC circuit. Power is connected to terminal block J2. A safety ground terminal is also provided on terminal block J2.

Power (LBW-420-1)

Power for the LBW-420-1 must be a DC voltage between 18 and 30 volts with a current rating of at least 0.5 amps at 24 volts. Power is connected to terminal block J2.

Jumper J3, Ammonia signal (LBW-420-1 only)

Jumper J3 (ammonia signal) configures the LBW-420-1 to use either an external power supply for the Ammonia 4-20 mA circuit or to use an on board 18 to 30-volt DC supply for the 4-20 mA circuits.

With the jumper in the leftmost position, connecting pins 2 to 3 (as shown in the picture on the next page) 4-20mA power is supplied by the on-board supply.

With the jumper in the rightmost position, connecting pins 2 to 1 (opposite of picture) 4-20 mA power must be supplied by an external supply.

NOTE: This detector does not support a 4 to 20mA output for the temperature sensor.

LBW-420-1 Enclosure Mounted Circuit Board

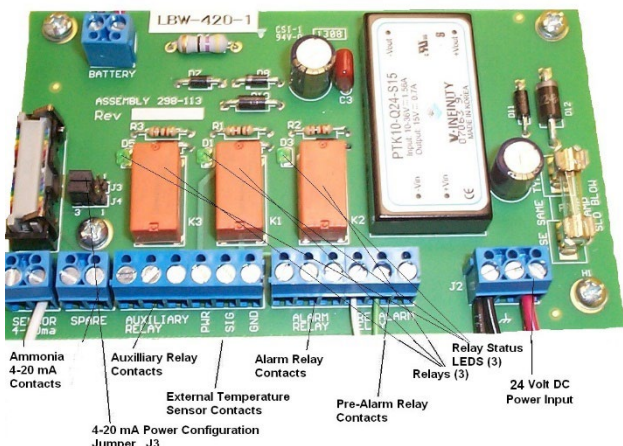

Jumpers Required

Jumpers J3 must be installed in either position. If the jumper is removed, the 4-20 mA circuit(s) will not function.

Relays

The detector has three miniature printed circuit board relays: the alarm, pre-alarm (early warning), and the auxiliary relays. The auxiliary relay operates as selected. (See pairing the Aux Relay) The factory default is for the auxiliary relay to operate only when there is an “Err” (error) with the detector. In the normal operating mode, the relays are energized in a normally-open state. If a loss of power to the detector occurs, the relays will de-energize and the alarms, if connected, will sound.

Relay Status LEDs

Each relay has a surface-mounted LED associated with it that indicates the status of the relay. A relay is energized (a non-alarm condition) when its LED is lighted (green), and de-energized (an alarm condition) when the LED is not lighted.

External Connections

Contacts for external connections:

- 4–20 mA outputs for ammonia level
- Auxiliary Relay contacts
- External temperature sensor input
- Alarm Relay contacts (Hi Alarm)
- Pre-alarm Relay contacts (Low alarm)
- LBW-420/-2 AC Power
- LBW-420-1 DC Power

4–20 mA Analog Outputs

The detector has a 4-20 mA analog output that allows it to communicate with external devices such as computers, PLCs, and digital displays. The output conforms to ISA S50.01 ratings, Type 2L and Type 2H (two-wire).

The ammonia level detector output current (TB2, “Sensor 4-20mA” terminals on lower left of Enclosure Mounted Circuit Board) is proportional to ammonia PPM with the proportionality constant dependent on the range. The PPM value can be determined using one of the following formulas:

$PPM = 62.5 (I - 4)$	0 to 1000 PPM Range
$PPM = 50 (I - 4)$	0 to 800 PPM Range
$PPM = 31.25 (I - 4)$	0 to 500 PPM Range
$PPM = 25 (I - 4)$	0 to 400 PPM Range
$PPM = 15.67 (I - 4)$	0 to 250 PPM Range
$PPM = 6.25 (I - 4)$	0 to 100 PPM Range

Where PPM equals ammonia concentration in parts per million and I equal the output current in mA.

Wiring Diagram: LBW-420

For the LBW-420, the 4-20 mA output is a simple series circuit that includes the detector, a 24 VDC power supply, and the receiving device. It is recommended that a 24 VDC, low-noise power supply be used for this application, although power supplies providing a minimum of 18 VDC to a maximum 30 VDC can be used. The voltage drop across the detector and the receiver together must not exceed the power supply voltage. This circuit is shown in Figure 1 below:

LBW-420

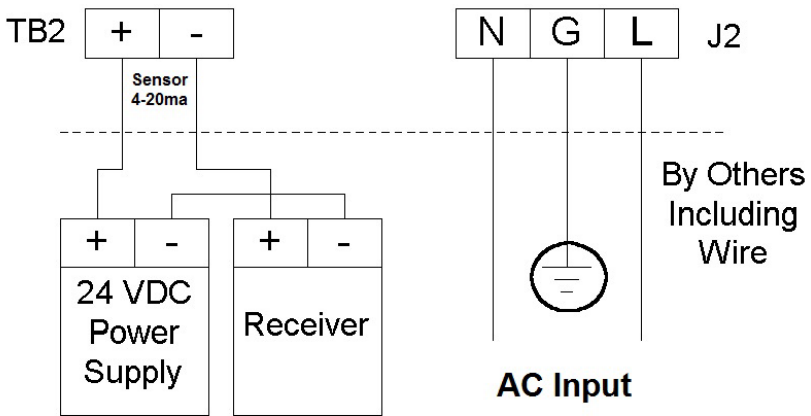

Typical 115/230 VAC Application

Figure 1.

Wiring Diagram: LBW-420-1 with (1) – 24 VDC Power Supply

For this configuration, with the jumper J3 in the leftmost position (which connects pins 2 & 3) power for the 4-20 mA circuit is provided by the LBW-420-1. This circuit is shown below. The power supply must supply all power for the LBW-420-1 plus the 4-20 mA circuit. Refer to the specifications page for the power requirements for the LBW-420-1. The voltage drop across the detector and the receiver together must not exceed the power supply voltage. This circuit is shown in figure 2 below:

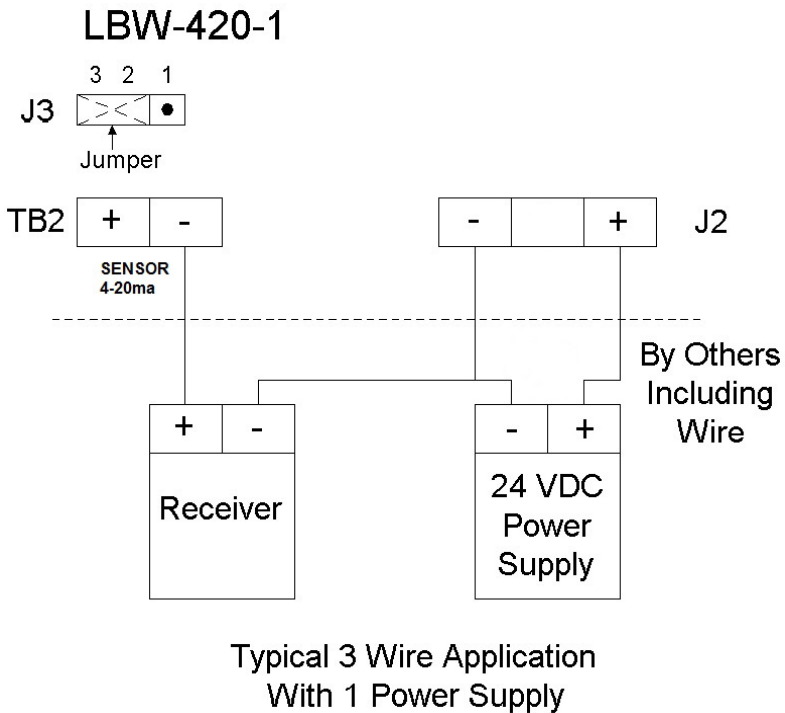
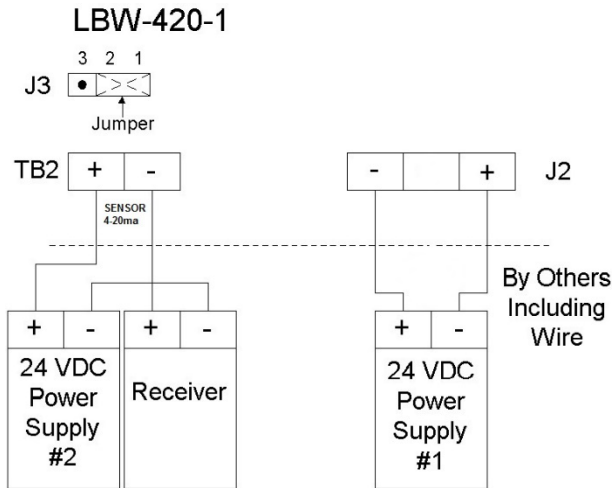

Figure 2.

Wiring Diagram: LBW-420-1 with (2) – 24 VDC Power Supplies

In this configuration, with the jumper J3 in the rightmost position (which connects pins 1 & 2), power for the LBW-420-1 is supplied by the 24 VDC power supply #1 only. The power supply must supply all power for the LBW-420-1. Refer to the specifications page for the power requirements for the LBW-420-1. The power for the 4-20 mA circuit is supplied by the 24 VDC power supply #2. The 4-20 mA circuit is a simple series circuit that includes the LBW detector, a power supply, and the receiving device. It is recommended that a 24 VDC low-noise power supply be used for this application, although power supplies providing a minimum of 10 VDC to a maximum 30 VDC can be used. The voltage drop across the detector and the receiver together must not exceed the power supply voltage. This circuit is shown in Figure 3 below:



Typical 4 Wire Application
With 2 Power Supplies

Figure 3.

For both the LBW-420, LBW-420-1 and the LBW-420-2, the maximum allowable resistance in the receiving device must not exceed R_{max} using this formula:

$$R_{max} = 50 (V_s - 7.5)$$

Where V_s is the supply voltage in volts DC for the 4-20 mA circuit. For example, with a supply voltage of 24 VDC, the maximum allowable resistance is 825 Ω .

INSTALLATION AND SETUP

Caution: Do not apply power to the detector until instructed to do so.

The detector comes with four mounting feet, packaged in the detector enclosure for shipment. Use the directions that accompany the mounting feet for mounting the detector enclosure.

Be sure the detector is visible and easily accessible. Avoid locating the detector where it might be damaged.

When power is applied to the detector, it may go into alarm status and the display will show an unusually large ammonia concentration. This is normal. When the sensor warms to normal operating temperature (usually about a minute) the detector will return to a non-alarm status. **For this reason, the detector should be placed in service mode before applying power to the detector to avoid nuisance alarms.**

The detector is calibrated and programmed at the factory. To program the detector for its specific installation, follow these steps in the order given:

1. Open the detector enclosure and place the detector in service mode by moving the service jumper to the "ON" position.

2. Apply power to the detector and allow the sensor to warm to normal operating temperature (at normal operating temperature, the display will read “0” and all Alarm LEDs will be unlit).
3. Program the ammonia Low alarm and High alarm set points. See the next section on programming the ammonia Low alarm and high alarm set points.
4. Program the external temperature sensor installation status to “installed” or “not installed”, depending on whether an external temperature sensor is installed. See the next section on programming the external temperature sensor installation status.
5. *Program* Set the detector to the desired operating display mode (typically “0” or “1”). See the next section on setting the display mode.
6. Be sure the displayed ammonia concentration is below the programmed Low alarm set point Return the detector to normal operating mode by moving the service jumper to the “OFF” position.
7. Test the detector to ensure it is operating correctly (but allow at least 20 minutes after power is first applied to the detector before testing). See the section on testing the detector.

PROGRAMMING AND OPERATION

The LBW-420 detector is easy to program and operate. Follow the instructions in this section to:

- Set the display mode
- Program the ammonia alarm set points
- Set the 4 to 20mA range
- Program the external temperature sensor installation status
- Set the Service mode time out
- Set the Aux Relay pairing
- Set relays latching Yes / No

Setting the Desired Display Mode

During normal operation, the rotary selector switch is typically set to position “0” or “1”. Set the switch to “0” to display ammonia concentration only, or to “1” to display ammonia concentration and external temperature (if an external temperature sensor is in use). If the rotary selector switch is set to “1”, the front panel digital display will alternate between ammonia concentration in PPM and external temperature in °F.

You can change when the display starts displaying the ammonia concentration. It can start displaying at 0PPM, 10PPM, or 25PPM.

With the SET jumper on and the Rotary Switch in position 7 you can use the up and down buttons to select either;

- d0 – Display shows all readings above 0PPM
- d10 – Display shows all readings above 10PPM
- d25 – Display shows all readings above 25PPM

Once you have selected the desired display property you must hold the ENTER button for two seconds before removing the SET 1 jumper or changing the rotary switch.

Programming the Ammonia Hi Alarm and Low Alarm Set Points

The Hi Alarm set point can be set from 5PPM to 1000PPM in 5PPM increments.

The Low Alarm set point can be set from 5PPM to 1000PPM in 5PPM increments.

The Low Alarm set point will always be less than or equal to the High Alarm set point. If the set points are equal then moving the High Alarm set point lower will lower the Low Alarm set point equally.

1. Open the detector enclosure and move the service jumper to the “ON” position.
2. Set the rotary selector switch to position “3” to program the ammonia the Hi-Alarm set point (ALARM RELAY) or “4” to

program the ammonia Low Alarm set point (PRE-ALARM RELAY).

3. Press the “UP” or “DOWN” button until the desired set point concentration in PPM is displayed.
4. Press and hold the “ENTER” button for at least 2 seconds. The new set point is now programmed.
5. Return the rotary selector switch to the desired position.
6. **Be sure the ammonia concentration reading is below the pre-alarm set point**, then move the service jumper to the “OFF” position and close the detector enclosure.

Programming the External Temperature Sensor Installation Status

Caution: A nuisance alarm will result if the external temperature sensor installation status is programmed to “F In” (installed) and an external temperature sensor is not installed.

The external temperature sensor installation status can be programmed to “F In” (installed) or “F --”(not installed), depending on whether an external temperature sensor is installed.

Programming the installation status requires the use of the jumper.

To program the external temperature sensor installation status, follow these steps:

1. Open the detector enclosure and move the service jumper to the “ON” position.
2. Install the jumper on the jumper pins (labeled “SET1”) located below the rotary switch on the front panel-mounted circuit board.
3. Set the rotary selector switch to position “5”. Press the “UP” or “DOWN” button until the display reads “F In” (installed) or “F --” (not installed).
4. Press and hold the “ENTER” button for at least 2 seconds. The new external temperature sensor installation status is now programmed.
5. Remove the jumper and return the rotary selector switch to the desired position.

6. **Be sure the external temperature reading is within the high and low temperature set points**, then move the service jumper to the “OFF” position and close the detector enclosure.

Programming the 4-20 mA range

The ammonia level 4-20 mA signal can be scaled to one of six ranges, either 0-100 PPM, 0-250 PPM, 0-400 PPM, 0-500 PPM, 0-800 PPM or 0-1000 PPM. The 0-250 PPM range is the default setting.

To program the 4-20 mA range, follow these steps:

1. Open the detector enclosure and move the service jumper to the “ON” position.
2. Install the jumper on the jumper pins (labeled “SET1”) located below the rotary switch on the front panel-mounted circuit board.
3. Set the rotary selector switch to position “3”. The display will indicate the current range, either “r100”, “r250”, “r400”, “r500”, “r800”, or “r1E3” (1000 PPM range).
4. Press the “UP” or “DOWN” button until the display indicates the desired range.
5. Press and hold the “ENTER” button for at least 2 seconds. The new range is now programmed.
6. Remove the jumper and return the rotary selector switch to the desired position.
7. Move the service jumper to the “OFF” position and close the detector enclosure.

Setting the Service Mode Timeout

If the service jumper is not returned to off, you can change how long the detector stays in service mode before returning to normal operating mode.

With the SET 1 jumper on and the Rotary Switch in position 4 you can use the up and down buttons to select either;

1Hr – After 1 Hour in the on position the detector will return to normal mode.

2Hr – After 2 Hours in the on position the detector will return to normal mode.

4Hr – After 4 Hours in the on position the detector will return to normal mode.

8Hr – After 8 Hours in the on position the detector will return to normal mode.

Once you have selected the desired service mode timeout you must hold the ENTER button for two seconds before removing the SET 1 jumper or changing the rotary switch.

Setting the Auxiliary Relay Pairing

The auxiliary relay will always activate when there is an error (Err on the display). In addition, you can select to have the auxiliary relay paired (activate at the same time) as either the Hi Alarm (alarm relay) or the Low Alarm (pre-alarm relay).

With the SET jumper on and the Rotary Switch in position 6 you can use the up and down buttons to select either;

AU – Auxiliary relay is not paired. Activates on errors only.

AUAL – Auxiliary relay is paired with the Hi Alarm (alarm) relay.

AUPR – Auxiliary relay is paired with the Low Alarm (pre-alarm) relay.

Once you have selected the desired service mode timeout you must hold the ENTER button for two seconds before removing the SET 1 jumper or changing the rotary switch.

Setting the relay latching

The Alarm (High Alarm) relay, Pre-Alarm (Low Alarm) relay, and AUX (Auxiliary) Relay and be set to latch “YES” or not latch “nO”

With the SET jumper off and the Rotary Switch in position 6 for AUX relay, 7 for Pre-Alarm relay, or 8 for Alarm Relay, you can use the up and down buttons to select either Latch “YES” or not latching “nO”

Once you have selected the desired latching mode you must hold the ENTER button for two seconds before removing the SET 1 jumper or changing the rotary switch.

Re-Setting a latched relay

Once the condition that cause the relay to latch, you can reset the latched relay by opening the cover and moving the “Service Mode Jumper” to the on position for 2 seconds then return the “Service Mode Jumper” to the off position.

Error Codes

In the event of a detector error, one of these error codes will be displayed on the front panel digital display possible causes are listed after the error description and are in order from most likely cause to least likely cause.

Error Code	Description
Err2	Loss of AC power occurs with battery back up or low ac input Defective Control display board (LBW-420-CDB) Defective Power Supply board (LBW-420-PSB-(Voltage))

Message Codes

If the service jumper is in the “on” position, the display message shows:

Message Code	Description
SER	Service jumper “on”

This is a reminder to move the service jumper to off, so the unit is in the normal operating mode. After the selected Service Mode Timeout, the detector will operate in as normal operation.

4-20 mA Error Indication

Any error condition will cause the ammonia level 4-20 mA signal to go to near zero indicating a fault.

TEST AND CALIBRATION

Be sure to follow all codes and company procedures that pertain to the maintenance, repair, testing, and calibration of all safety equipment, including this detector

At a minimum, the detector must be tested after installation and at least once a month in critical areas, once a quarter in non-critical areas, thereafter, to ensure it is operating correctly. Also, the detector must be calibrated at least once a year to ensure it is detecting and displaying ammonia concentration accurately.

At the time of calibration, it is highly recommended to use ammonia test gas that can be purchased from Cool Air Inc. or their distributors.

The detector is initially calibrated and programmed at the factory. However, if a new ammonia sensor is installed, the detector must be recalibrated.

All tests and calibrations must be recorded on an appropriate log sheet.

Testing the Detector

The detector hardware and the connected system response can be tested without exposing the sensor to ammonia. With the SET 1 jumper off, rotate the rotary switch to position 5. Pressing the “DOWN” button will force the detector to simulate an ammonia concentration equal to the LOW Alarm Set Point. Pressing the “UP” button will force the detector to simulate an ammonia concentration equal to the HI Alarm Set Point. The 4 to 20mA output current will indicate the simulated ammonia concentration according to the 4 to 20mA range selected.

To test the detectors response to ammonia (for best results, allow at least 20 minutes after first applying power to the detector):

1. Open the detector enclosure and move the service jumper to the “ON” position, if needed. This step deactivates the Pre-Alarm, Alarm, and Auxiliary relays so that any attached strobe lights, horns, and/or monitoring systems are not activated. In some

applications, if alarming is required, leave the service jumper in the “OFF” position.

2. Apply span gas (equal to or greater than the High Alarm Set Point) at 0.3 L/min (span gas must be in air, not nitrogen or another carrier).
3. Check the following:
 - When the ammonia concentration reaches the Low Alarm, set point the Low Alarm (yellow) LED will light.
 - When the ammonia concentration reaches the Alarm, set point the Alarm LED (red) will be on.
 - Digital display shows an increasing concentration of ammonia in PPM.
 - When **NOT** in service mode the 4-20 mA output signal shows an increasing value that corresponds to the digital display per the 4 to 20mA range selected.
 - NOTE: If the relays are set to latch they will require reset after the gas concentration is below the set point (see Re-setting a latched relay)
4. Remove the ammonia test gas.
5. **Wait until the ammonia concentration reading is below the pre-alarm set point**, then move the service jumper to the “OFF” position and close the detector enclosure. Remember, this step is only required if the service jumper was moved to the “ON” position in step # 1 above. Testing is now complete.

Calibrating the Detector

Zero offset adjust

If after the prescribed 20 minutes warm up the detector is not reading zero, follow these instructions to adjust the zero offset.

1. Open the detector enclosure and move the service jumper to the “ON” position, if needed. This step deactivates the pre-alarm, Alarm, and Auxiliary relays so that any attached strobe lights, horns, and/or monitoring systems are not activated. In some applications, if alarming is required, leave the service jumper in the “OFF” position.

2. Install the jumper on the jumper pins (labeled “SET1”) located below the rotary selector switch on the front panel-mounted circuit board.
3. Set the rotary selector switch to position “2”.
4. Press and hold the “ENTER” button for 2 seconds.
5. The display should now read zero.

When installing a new sensor follow these instructions

1. Open the detector enclosure and move the service jumper to the “ON” position, if needed. This step deactivates the pre-alarm, Alarm, and Auxiliary relays so that any attached strobe lights, horns, and/or monitoring systems are not activated. In some applications, if alarming is required, leave the service jumper in the “OFF” position.
2. Install the jumper on the jumper pins (labeled “SET1”) located below the rotary selector switch on the front panel-mounted circuit board.
3. Set the rotary selector switch to position “2”.
4. Press and hold the “DOWN” button for 2 seconds. This clears the zero offset so it can be reset (if necessary, for the new sensor)
5. If the display does not read zero refer to the **Zero offset adjust** section.

Follow these instructions to calibrate the detector:

1. Open the detector enclosure and move the service jumper to the “ON” position, if needed. This step deactivates the pre-alarm, Alarm, and Auxiliary relays so that any attached strobe lights, horns, and/or monitoring systems are not activated. In some applications, if alarming is required, leave the service jumper in the “OFF” position.
2. Install the jumper on the jumper pins (labeled “SET1”) located below the rotary selector switch on the front panel-mounted circuit board.
3. Set the rotary selector switch to position “9”.
4. Apply span gas certified span gas at 0.3 L/min (span gas must be in air, not nitrogen or another carrier) until a stable ammonia concentration reading is displayed. It might take

several minutes for the reading to stabilize this should be at a maximum 2 minutes.

5. Press the “UP” or “DOWN” button until the display indicates the concentration of the known sample. For example, if the sample ammonia concentration is 100 PPM, press the “UP” or “DOWN” button until the display indicates 100 PPM.
6. Press and hold the “ENTER” button for at least 2 seconds.
7. Remove the span gas.
8. Set the rotary selector switch to the desired position (typically “0” or “1”).
9. Wait until the ammonia concentration reading is below the pre-alarm set point, then move the service jumper to the “OFF” position and close the detector enclosure. Remember, this step is only required if the service jumper was moved to the “ON” position in step # 1 above. Testing is now complete.

TECHNICAL SUPPORT

For technical support, contact Cool Air Incorporated using any of these methods:

Phone: (763) 205-0844 (USA)

Fax: (763) 432-9295 (USA)

E-mail: info@coolairinc.com

Web site: www.coolairinc.com

Address: Cool Air Incorporated
1544 134th Ave NE
Ham Lake, MN 55304
USA

Testing and maintenance supplies;

- Calibration and test kit P/N CAI-CAL-KIT
- Cal Adaptor for Electrochemical Sensor P/N EC-CAL-ADPT
- 0 to 500 PPM Electrochemical Sensor P/N NH3-420-EC
- Ammonia 100 PPM Calibration Gas Balance Air in a 34 Liter Aluminum Cylinder Connection Type C-10 P/N TG-100-34L
- Ammonia 250 PPM Calibration Gas Balance Air in a 34 Liter Aluminum Cylinder Connection Type C-10 P/N TG-250-34L
- Ammonia 500 PPM Calibration Gas Balance Air in a 34 Liter Aluminum Cylinder Connection Type C-10 P/N TG-500-34L
- .3LPM, Toggle on flow valve, C10 inlet, 3/16" barb outlet, nickel plated brass P/N FLOW-REG-.3

WARRANTY

36-Month Limited Warranty & Limitation of Liability

1. Limited Warranty
Cool Air incorporated (CAI) warrants to the original purchaser and/or ultimate customer ("Purchaser") of CAI ammonia leak detector ("Product") that if any part thereof proves to be defective in material or workmanship within thirty-six (36) months from the date of shipment, such defective part will be repaired or replaced, free of charge, at CAI's discretion if shipped prepaid to CAI at 1544 134th Avenue NE, Ham Lake, MN 55304, in a package equal to or in the original package. Before making the return shipment, contact CAI @ 763-205-00844 to request an RMA # to be prominently displayed on the returned package. The product shall be returned freight prepaid and repaired or replaced if it is determined by CAI that the part(s) failed due to defective materials or workmanship. The repair or replacement of any such defective part shall be CAI's sole and exclusive responsibility under this limited warranty.

2. Inclusions:
 - A. As of September 2, 2014, the defined Product that is covered by this thirty-six (36) month limited warranty is the LBW-50, LBW-420, LBW-420-1, LBW-RLV, and DCSAP.
 - B. If an ammonia gas sensor is part of the Product, the ammonia gas sensor is covered by the same thirty-six (36) month limited warranty offered by CAI.
 - C. For this thirty-six (36) month limited warranty to be fully effective, the Purchaser shall be responsible for following the manufacturer's recommended monthly bump testing in critical areas, every 3-months bump testing in non-critical areas, and annual or twelve (12) month calibration service, which shall include proof of recordkeeping for testing and calibration by the Purchaser.

3. Exclusions:
 - A. If an ammonia gas sensor is covered by this thirty-six (36) month limited warranty, the ammonia gas sensor shall be subject to inspection by CAI for abuse, misuse, negligence, damage by accident, abnormal conditions of operation, handling or use by the Purchaser. Should such inspection indicate that the ammonia sensor has prematurely failed due to abuse, misuse, negligence, or damage by accident or abnormal conditions of operation, handling or use by the Purchaser, this limited warranty shall not apply to the ammonia gas sensor.
 - B. This thirty-six (36) month limited warranty does not cover consumable items such as back-up batteries or ammonia test bottles.

4. Warranty Limitation, Inclusions, & Exclusions:

Cool Air Incorporated shall have no further obligation under this limited warranty. All warranty obligations of Cool Air Incorporated are extinguishable if the Product has been subject to abuse, misuse, negligence, or damage by accident or abnormal conditions of operation, handling or use by the Purchaser or if the Purchaser fails to perform any duties set forth in this limited warranty or if the

Product has not been operated in accordance with the instructions, or if the Product serial number has been removed or altered.

6. Disclaimer of Unstated Warranties

THE WARRANTY PRINTED ABOVE IS THE ONLY WARRANTY APPLICABLE TO THIS PURCHASE. ALL OTHER WARRANTIES, EXPRESS OR IMPLIED, INCLUDING, BUT NOT LIMITED TO, THE IMPLIED WARRANTIES OF MERCHANTABILITY OR FITNESS FOR A PARTICULAR PURPOSE ARE HEREBY DISCLAIMED

7. Limitation of Liability

IT IS UNDERSTOOD AND AGREED THAT COOL AIR INCORPORATED'S LIABILITY, WHETHER IN CONTRACT, IN TORT, UNDER ANY WARRANTY, IN NEGLIGENCE OR OTHERWISE SHALL NOT EXCEED THE AMOUNT OF THE PURCHASE PRICE PAID BY THE PURCHASER FOR THE PRODUCT AND UNDER NO CIRCUMSTANCES SHALL COOL AIR INCORPORATED BE LIABLE FOR SPECIAL, INDIRECT, OR CONSEQUENTIAL DAMAGES. THE PRICE STATED FOR THE PRODUCT IS A CONSIDERATION LIMITING COOL AIR INCORPORATEDS' LIABILITY. NO ACTION, REGARDLESS OF FORM, ARISING OUT OF THE TRANSACTIONS UNDER THIS WARRANTY MAY BE BROUGHT BY THE PURCHASER MORE THAN FIVE YEARS AFTER CAUSE OF ACTIONS HAS OCCURRED.

COOL AIR

INCORPORATED

1544 134th AVE NE, Ham Lake, MN 55304 USA

Phone (763) 205-0844 Fax (763) 432-9295

info@coolairinc.com

www.coolairinc.com